



# *Rio*

## Espresso & Chocolate



# User Manual

## Super-automatic Coffee Machine



**One-Touch Drinks**

P.O Box 118300  
Carrollton, TX 75011-8300

(800) 560-5062  
Technical support: x3

onetouchdrinks.com  
info@onetouchdrinks.com  
onetouchdrinks.com

For best results, Rio is recommended for use  
with One-Touch Drinks consumable products.

**To order, go to:** [onetouchdrinks.com](http://onetouchdrinks.com)

Or, call: (800) 560-5062

# Rio User Manual

<b>WARNINGS</b> .....	<b>4-5</b>
<b>CHAPTER 1. GENERAL CHARACTERISTICS</b> .....	<b>6</b>
1.1.- Description of the machine. ....	6
1.2.- Description of the main components.....	7
<b>CHAPTER 2. INSTALLATION AND STARTING-UP</b> .....	<b>8</b>
2.1.- Choice of location for the machine.....	8
2.2.- Electrical installation .....	8
2.3.- Start-up.....	8
2.4.- Water supply.....	8
2.5.- Payment module .....	8
<b>CHAPTER 3. DESCRIPTION OF THE MACHINE</b> .....	<b>9</b>
3.1.- Soluble product hoppers.....	9
3.2.- Initial loading of soluble product.....	9
3.3.- Loading coffee beans.....	9
3.4.- Initial loading of water .....	9
3.5.- Programming the water temperature under special conditions .....	10
3.6.- Bean coffee group (Espresso Machines).....	10
3.7.- Dismantling the coffee bean group .....	11
3.8.- Settings and adjustments.....	11
<b>CHAPTER 4. PROGRAMMING</b> .....	<b>13</b>
4.1.- How do we communicate with the machine? .....	13
4.2.- What can be programmed? .....	13
4.3.- Programming menu .....	13
4.4.- List of functions .....	14-15
4.5.- Customising the Programming Menu.....	16
4.6.- Service programming.....	16-18
<b>CHAPTER 5 – TROUBLESHOOTING AND MAINTENANCE</b> .....	<b>19</b>
5.1 - Reset .....	19
5.2.- Error detected by the machine.....	19
5.3.- Changing the product labels .....	20
<b>CHAPTER 6. CLEANING THE MACHINE</b> .....	<b>21</b>
6.1.- Components that require regular cleaning .....	21
6.2.- Regular cleaning of the machine and maintenance operations .....	22
6.3.- Cleaning cycle for the group brewing chamber .....	22
6.4.- Descaling cycle.....	24
6.5.- Replacing the water filter .....	25
6.6.- Exterior cleaning .....	25
<b>Anexe 1. THE TREATMENT, COLLECTION, RECYCLING AND DISPOSAL OF THE DEVICE</b> .....	<b>26</b>
<b>UE Declaration of Conformity</b> .....	<b>27</b>

**BEFORE USING THIS MACHINE, THIS MANUAL MUST BE READ CAREFULLY.** THE INSTALLATION AND OPERATIONS REQUIRED FOR INITIAL START-UP OF THE MACHINE MUST BE PERFORMED BY QUALIFIED PERSONNEL.

- This manual is an integral part of the machine, and as such, it must always remain nearby the machine so that it may be referred to at any time.
- This automatic drink dispenser has been designed and built in accordance with all safety legislation in force.
- The manufacturer hereby guarantees that these machines comply with the following directives:



CE Low Voltage Directive DBT 73/23/CEE and its amendments

CE Electromagnetic Compatibility Directive EMC 89/336/CEE and its amendments

CE Machinery Directive 2006/42/EC and its amendments

- This document contains private property information protected by legislation on intellectual property. All rights are hereby reserved. No part of this document may be photocopied, reproduced or translated without the prior written consent of the manufacturer.
- The manufacturer hereby declines all liability for damages caused to persons or things as a result of the following:
  - Incorrect installation
  - Inadequate electrical and/or hydraulic installation
  - Deficient cleaning or maintenance
  - Incorrect use of the machine
  - Using non-original replacement parts or making unauthorized modifications
- The manufacturer hereby reserves the right to introduce, without prior notice, all improvements to this model derived from its constant research.
- This appliance is not designed to be used by persons (including children) with reduced physical, sensory or mental capabilities, lack of experience or knowledge, unless they are supervised or have been instructed in its use by somebody responsible for their safety.
- Children should be supervised to ensure that they do not play with the appliance. Section 7.12 of EN60335.
- Given the characteristics of some food products, these may lead to incorrect operation of the machine if used beyond the parameters of temperature and relative humidity recommended in this manual.  
If it is necessary to move the machine avoid:
  - Tipping the machine
  - Dragging or lifting it with some kind of pulling system (rope, straps, etc.).
  - Shaking or striking the machine, no matter whether it is in protective wrapping or not.

## Installation

- These machines are designed **EXCLUSIVELY FOR INDOOR USE**. They must not be installed in places that may be exposed to sprayed water, and they likewise must not be cleaned using sprayed water.
- The machine should be installed in locations that meet the recommendations of temperature, electrical and water installations, weights, etc., in this manual and performed by qualified personnel.
- The plug of the machine has an earth connection. The outlet must be connected to a good earth connection and must be located in an accessible position once the machine is installed.



## Cautions - con't

### Maintenance

- The user or person responsible for refilling and cleaning the device must follow the instructions set forth in this manual.
- For refilling, only use food products prepared specifically for these kinds of vending machines. Do not touch the product with your hands, and prevent liquids from falling inside the product hoppers.
- All elements that require tools to be disassembled must only be handled by qualified and trained technical personnel.
- **Water must be prevented from freezing in the interior of the machine.** If any maintenance task is going to be performed and the machine is going to be disconnected for a long period of time, the boiler must be emptied.

THESE MACHINES SHOULD NOT BE INSTALLED IN PLACES WHERE THEY MAY BE EXPOSED TO STREAMS OF WATER, NOR SHOULD THEY BE CLEANED BY HOSE. CONSULT THE EXTERIOR CLEANING SECTION FOR THOSE INSTRUCTIONS.

### Electrical

- **THE MACHINE HAS COMPONENTS THAT OPERATE AT DANGEROUS VOLTAGES. DO NOT DISCONNECT ANY COMPONENT. ONLY TECHNICAL SERVICE PERSONNEL ARE AUTHORIZED.**
- Ensure that the electrical installation, the outlet and the automatic circuit breaker have the appropriate sizes for machine consumption.

### Symbols used on the machine



This symbol on a label indicates if you need more information, it can be found in the User Manual.

FOR ANY ADDITIONAL INFORMATION THAT IS NOT SPECIFIED HEREIN,  
CONTACT YOUR DISTRIBUTOR OR A MANUFACTURE TRAINED TECHNICIAN

## CH 1- GENERAL CHARACTERISTICS

### 1.1.- Description of the machine

The machines in the Rio range are TABLETOP coffee and soluble beverage machines especially designed for use in areas with medium coffee consumption, such as waiting rooms, medium-sized offices, etc.

**There are three machine configuration options:**

1) **Espresso + 2**, with two soluble product containers and coffee-bean system.

Not available in the US:

2) **Espresso**, fitted with a system to make espresso coffee from coffee beans

3) **Instant**, only with soluble products



**Espresso**



**Espresso+ 2**



**Instant**

	Espresso	Espresso+2	Instant
No. of selections	<b>4</b>	<b>8</b>	<b>8</b>
<b>Product</b>			
No. bean containers	<b>1</b>	<b>1</b>	<b>0</b>
No. soluble product containers	<b>0</b>	<b>2</b>	<b>4</b>
Bean container capacity (l.)	<b>3.1 l</b>		-
Soluble product container capacity (l)	-	<b>1.6 l</b>	
<b>Dimensions</b>			
Height	<b>24 in</b>		<b>23.8 in</b>
Width	<b>12 in</b>		
Depth	<b>17 in</b>		
Weight	<b>43.43 lb</b>	<b>60 lb</b>	<b>53.5 lb</b>
<b>Electrical characteristics</b>			
Voltage	<b>according to the characteristics plate (+6V/-10V)</b>		
Maximum Power consumption (W)	<b>&lt; 1500W</b>		
<b>Water supply</b>			
Types of supply	<b>Mains or incorporated tank</b>		
Minimum input pressure	<b>Min 7.2 lbs- max. 40 lbs</b>		

Diameter of the stopcock (to connect the mains hose)	¾" M
Water tank capacity (l)	4
Other Characteristics	
Maximum work gradient	2° (on any axis)
Sound level	<80 dB(A)
Optimum exterior environment temperature	> 1°C - <40°C; <65% Rel. hum.

## 1.2.- Description of the main components



**Fig. 1**

1. Coffee bean container
2. Soluble product container
3. Ground coffee doser
4. Soluble product blender
5. Coffee bean group
6. Rubber threshold
7. Drip tray
8. Programming button ("PROG")
9. Display
10. Selection buttons
11. Cup holder
12. Suction tube
13. Tray full level
14. Water tank

## CH 2- INSTALLATION AND STARTING-UP

### 2.1 Choice of location for the machine

The machine must be placed on a unit or support so that it is stable and cannot be accidentally knocked over. The support must be well secured to the wall.



**THE INSTALLATION OPERATIONS REQUIRED FOR THE INITIAL START-UP OF THESE MACHINES MUST BE PERFORMED BY QUALIFIED TECHNICAL STAFF.**

### 2.2 Electrical installation

The voltage of the electrical system must comply with the voltage indicated on the characteristics plate on the back of the machine and must not exceed the limits set in the country of use.

Maximum power consumption is indicated on the machine characteristics plate.

### 2.3 Start-up

Once the tank has been filled or the water hose has been connected to the mains and current fed to the socket, close the door: The machine will be ready for use in a few minutes.

Press the switch on the back of the machine.

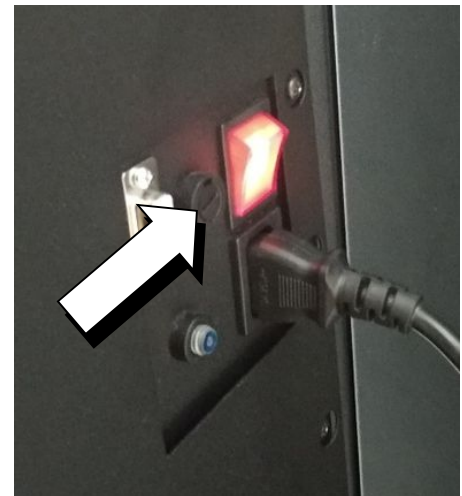

### 2.4 Water supply

If your machine is fitted with mains service, then prepare a

water supply where the machine is to be fitted in accordance with the indications in the general characteristics table. The distance between this water supply and any electric socket base must be at least 1 meter (3.3 ft) observed by European directives.

If your machine is fitted with a water tank, remove it from the side of the machine for filling.



***WHEN CONNECTING THE MACHINE and it STARTS FILLING THE WATER CIRCUIT, DO NOT REMOVE THE CONTAINER UNTIL THE OPERATION IS COMPLETE.***

### 2.5 Payment module

The machine can feature an optional payment module, which supports connection of a validator with MDB protocol. The installation instructions are included in the corresponding kit.

**RIO CAN ONLY BE POWERED WITH 24DC (NOT WITH 24VAC).**

## CH 3- DESCRIPTION OF THE MACHINE

### 3.1 Soluble product hoppers

The Instant and Espresso+2 machines have 2 or more soluble product containers.

These containers extract the product via a spindle to the blender, where it is mixed with water sent from the boiler.

Each hopper must always be loaded with the same type of product because the serving configuration activates the hopper programmed for each case.

e.g. Do not load the coffee hopper with a different product because the machine will use it for servings programmed with coffee.

### 3.2 Initial loading of soluble product.

Lift the lid of the hopper to be loaded and load the product. Make sure that the product loaded is the right product for the hopper (each hopper has a label indicating the product to load).

When the product has been loaded, close the lid and proceed to load the next hopper.



### 3.3.- Loading coffee beans

Lift the hopper lid and pour in the contents of the packet of coffee to the desired level.

### 3.4.- Initial loading of water

All the machines automatically fill the boiler when the machine is started up.

**BEFORE CONNECTING THE MACHINE, MAKE SURE THAT THERE IS WATER AVAILABLE TO FILL THE BOILER (check the mains hose connection or make sure that the water tank is full)**

### 3.5 Programming the water temperature under special conditions

The machine is programmed at the factory with a 185°F/85°C boiler temperature by default. The water boiling point can be much less than 212°F/100°C in some cities, according to their altitude. Malfunction of the hydraulic system of the unit can be caused if the temperature of the machine is modified to higher water boiling temperatures. Examples:

Altitude over sea level (feet/meters)	Temp. Water boiling Fahrenheit/Celsius	Temp. Max. recommended of the boiler (Function 461)
4921 ft/ 1500 m	203°F/ 95°C	197.6°F/ 92°C
5905 ft/ 1800 m	201.2°F/ 94°C	195.8°F/ 91°C
6890 ft/ 2100m	199.4°F/ 93°C	194°F/ 90°C
7874 ft/ 2400 m	197.6°F/ 92°C	192.2 °F/ 89°C
8858 ft/ 2700 m	195.8°F/ 91°C	190.4 °F/ 88°C

### 3.6 Coffee Bean Group (Espresso Machines)

The coffee beans are stored in the grinder hopper. When a serving is requested, the brewing group moves to the loading position and the grinder grinds the amount of coffee programmed, sending it to the doser, where the coffee is dosed and then falls to the brewing piston.

The group then advances to the brewing position and the piston tamps the coffee.

The pump injects the programmed water into the group for the pre-set length of time. The result of this operation is the Espresso coffee which pours into the cup.

Fig. 2

- 1 Hopper
- 2 Doser
- 3 Upper piston
- 4 Lower group
- 5 Group anchoring lever
- 6 Grinder adjustment lever
- 7 Coffee outlet tube
- 8 Group positioning crank

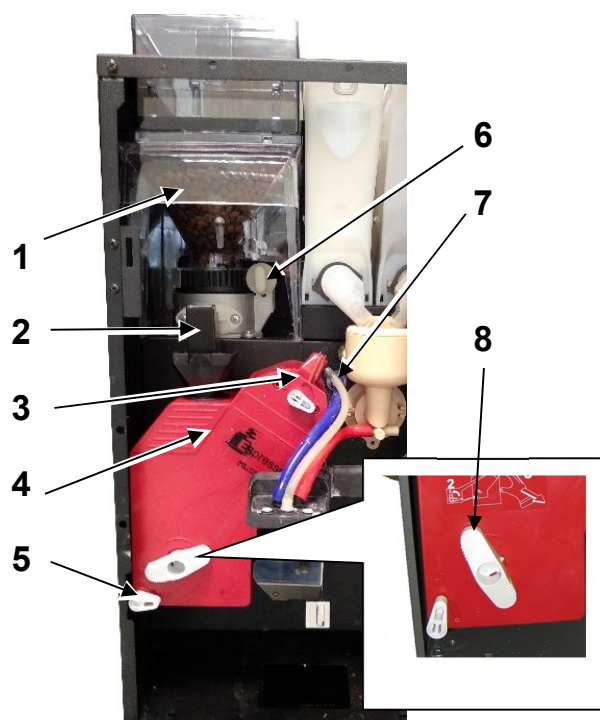

### 3.7 Dismantling the coffee bean group

To extract the brewing piston:

1. Set the group to stand-by position by entering programming and pressing button 6 (see programming).
2. Remove the securing pin.
3. Pull the piston upwards.
4. If you wish to dismantle the piston completely, remove the securing clip.

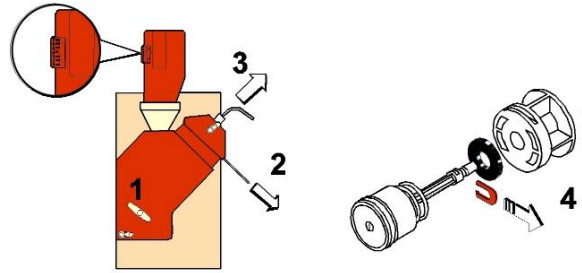

If you wish to **dismantle the entire lower group**, dismantle the group water input hose and then turn the group securing levers and extract the group by pulling it out.

### 3.8 Settings and adjustments

**Adjusting the coffee dose in espresso machines WITH a dosing system.** The brewing piston on the group has a washer with which it is possible to increase or decrease the capacity of the brewing cylinder and thereby adjust the amount of ground coffee it can contain. The quantity can vary between 5g and 8g. The doser also needs to be adjusted so as to send the right amount to the cylinder.

The following diagram indicates the position of the washer and the doser lever to set the desired amount.

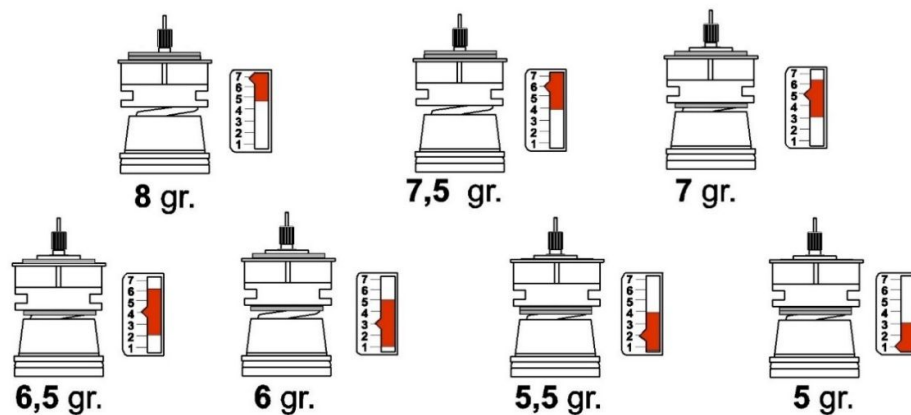

The dose is factory set to 6.5 g of ground coffee (100 % natural coffee)



**Adjusting the coffee dose in espresso machines WITHOUT a dosing system.** The grinder must be calibrated in machines without a dosing system using function F030.

After it has been calibrated, the grinder will adjust the coffee dose after each service, as programmed with function 315.

For example: every 2.45 seconds of operation of the grinder will produce an amount equivalent to 7 g.

**IMPORTANT:** The washer position must be adjusted as indicated in the above diagram. If not, the unit might malfunction and faults might even be caused.

#### **Calibrating the grinder.**

- 1** Remove the coffee grinder unit, as described in point 3.7.
- 2** Access the programming menu (see Chap. 4) and select function F030. Press the A and B buttons until the display shows "GRINDER". Next, press the D button.
- 3** The machine will grind and extract coffee during 10 seconds. Place a container at the grinder outlet to collect the ground coffee.
- 4** Weigh the extracted product and enter the value using buttons A and B. Validate using button D.

The machine will now indicate the weight of the product in grams.

**Coffee grinding point adjustment.** The grinder leaves the factory set to the optimum grinding position. If you want to grind the coffee finer, then you can move the adjustment lever one or two positions (with the motor running to prevent the teeth from jamming with coffee).

The grinder adjustment lever is at the top of the group. Use it to set the ground coffee grade you wish to use.

A "good coffee" is one which has been brewed at 9 kg/cm<sup>2</sup>, which is equivalent to a brewing time of between 15 and 20 sec.



## CH 4- PROGRAMMING

### 4.1 How do we communicate with the machine?

Rio machine uses a selection keypad to communicate with the machine user.

When the machine is in programming status, the programmable functions are accessed by pressing the different buttons.

The machine has an information screen which shows messages during service, programming and warning messages for maintenance and cleaning.

### 4.2 What can be programmed?

To access the programming screen, press the **“PROG”** button on the inside of the door (Fig. 1).

The PROG button can also be used to exit the programming mode.

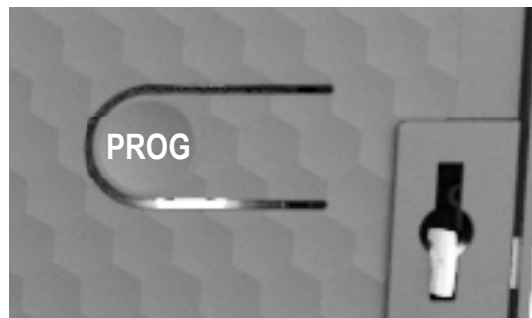

### 4.3 Programming menu

Rio units will be programmed from the display of the machine.

Press the selection buttons on the top row of the panel to programme the machine, edit its values, etc.

The buttons behave as follows in the programming mode:



<b>Button A</b>	Function goes forward
<b>Button B</b>	Function goes backward
<b>Button C</b>	Exits the programming
<b>Button D</b>	Accesses the function that is displayed at that moment or executes the function automatically (EXE mode)
<b>Button E</b>	Free Sale (1 service)
<b>Button F</b>	Mixer washing
<b>Button G</b>	Boiler water temperature
<b>Button H</b>	Not used

Some buttons will have different functions and perform different actions:

Alfanumerical (AB1)	Button A	The digit being edited goes up one character in the table.
	Button B	The digit being edited goes down one character in the table.
	Button C	Erase the digit being edited, and it returns to editing the previous digit.
	Button D	The character is validated, and it goes to editing the next digit.
	PROG	Stops the editing process, saving the information on the display
Numerical (001)	Button A	Increases the digit being edited (if it is a sign, it changes)
	Button B	Decreases the digit being edited (if it is a sign, it changes)
	Button C	It returns to editing the previous digit (if it is the first number, it edits the sign, and if it is the sign, it exits and validates)
	Button D	It advances to editing the next digit (if it is the first number, it edits the sign, and if it is the sign, it exits and validates)
	PROG	Stops the editing process, saving the information on the display
Options List (ABC)	Button A	The next option on the list is accessed (if it is the last option, it goes to the first).
	Button B	The previous option on the list is accessed (if it is the first option, it goes to the last)
	Button C	It goes up one execution level
	Button D	Validates the value shown on the display and exits the function

## 4.4 List of functions

The full list of functions of the machine and their edit mode are shown below.

Función	Descripción	Modo Edición
F010	LISTING	ABC
F030	MACHINE TEST	ABC
F090	SW.VERSIONS	ABC
F091	INITIALISATION	EXE
F110	SALES BY SELECTION (CASH)	EXE
F111	SALES BY SELECTION (UNITS)	EXE
F113	SALES PER SELECTION UNDER FREE SALE	EXE
F120	TOTAL AMOUNT OF SALES	EXE
F121	TOTAL UNITS SOLD	EXE

## Rio User Manual

<b>Función</b>	<b>Descripción</b>	<b>Modo Edición</b>
<b>F122</b>	TOTAL SALES UNDER FREE SALE	EXE
<b>F141</b>	CASH IN COIN BIN	EXE
<b>F142</b>	CASH IN THE RETURNER TUBES	EXE
<b>F145</b>	CASH DISPENSED MANUALLY	EXE
<b>F146</b>	VALUE OF CHANGE NOT GIVEN	EXE
<b>F147</b>	MONEY IN CREDIT WITHDRAWN FROM PREPAID CARDS	EXE
<b>F148</b>	CASH COLLECTED FOR PREPAID CARD RECHARGES.	EXE
<b>F149</b>	CASH IN BILLS	EXE
<b>F171</b>	DELETES ACCOUNTED	EXE
<b>F180</b>	PERPETUAL ACCOUNTING OF TOTAL SALES	EXE
<b>F191</b>	PERPETUAL ACCOUNTING OF SALES, BY SELECTION (UNITS)	EXE
<b>F201</b>	PRICES WITH COINS	001
<b>F204</b>	SINGLE PRICE FOR ALL SELECTIONS	001
<b>F220</b>	FREE SALE	ABC
<b>F221</b>	MULTIVEND	EXE
<b>F300</b>	SELECTION-SERVICE ASSOCIATION	AB1
<b>F315</b>	PROP SERVICE PROGRAMMING	Ver 4.6
<b>F317</b>	PROP PRE-SELECTION PROGRAMMING	
<b>F401</b>	MACHINE TYPE	ABC
<b>F412</b>	INPUT COINS (BLOCKING/VALUE)	ABC
<b>F416</b>	MAXIMUM ALLOWED PER TYPE OF COIN	001
<b>F418</b>	COIN ADMISSION OUT OF CHANGE	001
<b>F419</b>	OUT OF CHANGE CALCULATION FUNCTION	ABC
<b>F420</b>	ADVERTISING MESSAGE	AB1
<b>F421</b>	SPECIAL EFFECT MESSAGE	AB1
<b>F424</b>	OUT-OF-SERVICE MESSAGE	AB1
<b>F430</b>	LANGUAGE	AB1
<b>F431</b>	NAME OF THE MONETARY UNIT	AB1
<b>F432</b>	NUMBER OF DECIMALS	001
<b>F454</b>	CARD READER	ABC
<b>F455</b>	BILL READER	ABC
<b>F461</b>	BOILER TEMPERATURE	ABC
<b>F463</b>	AUTOMATIC WASH	001
<b>F465</b>	STAND ALONE UNIT YES/NO	ABC+001
<b>F472</b>	OPERATOR CODE (4 DIGITS)	ABC
<b>F490</b>	NAME OF THE HOPPERS	AB1
<b>F491</b>	NAME OF THE SERVICES	AB1

**Remember that you can only use the functions shown in the Programming Menu**

## 4.5 Customising the Programming Menu

The machine has many different internal programming functions. However, you can only use the functions shown in the Programming Menu and those displayed when the programming screen is displayed.

The Programming Menu can be customised. You can add or delete the functions of this menu to customise it.

### To customise the menu:

Hold down the PROG button for 5 sec. The full list of functions of the machine will be displayed. You can browse the list of functions with the A and B buttons.

The screen will show whether the function is included in the programming menu or not, adding a “P” between the function number and its text box.



010 P LISTINGS

Or “-” if it is not included



010 - LISTINGS

Press the D button to change the value of this digit.

Press the A or B button to save and edit a different function.

Press C to save the value and exit the programming menu.

## 4.6 Service programming

### 4.4.1 What is a service?

A service is the act that the machine performs every time that a customer presses a selection. More specifically, a service is the steps that the machine must take in order to complete the operation that has been selected.

Therefore, when programming a service, each one of these steps must be programmed. For example: At home, when you prepare a soluble coffee with milk, various actions must be taken:

- 1) Put coffee in a cup.
- 2) Add sugar.
- 3) Add hot water.
- 4) Stir the mixture.
- 5) Add milk.

It is also a good idea for the actions to overlap each other in order to shorten the service time and to get the optimum mixture.

## Rio User Manual

The service sequence of coffee with milk in the machine could thus be stated as follows:

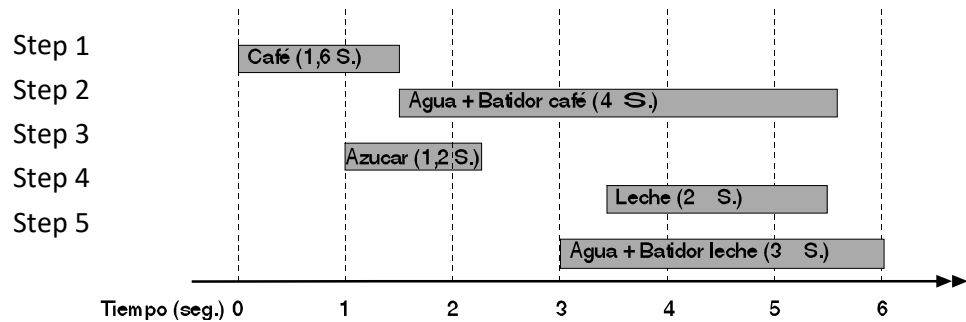

### 4.6.2 Function 315 PROG. SERVICE.

The complete configuration of each service can be programmed at function 315.

Within this configuration, you can program the various steps that the machine must perform in order to provide that service, the time that it starts during the service and the duration.

Once function 315 is accessed, choose the service to program, pushing the corresponding selection button.

The following may subsequently be performed:

- MODIFY** an already-programmed step.
- ADD** a new step to a service, or
- DELETE** a step from a service.

Pass from one step of the service to another by pressing buttons A and B (up/down respectively) and then button C to select the step displayed on the screen.

If the option, **MODIFY A STEP**, is selected, the machine will display the CONFIGURATION SCREEN of the step:

<b>HOPPER</b>	<b>ACTION</b>
<b>ST: 00.0</b>	<b>ET: 00.0</b>

Where:

**HOPPER** is the name of the hopper that is going to be used.

**ACTION** is the type of operation that is going to be performed with that hopper (add water, product...).

**ST** The start time of the action, which starts counting as from the moment the machine is in the service position. Two whole numbers and one decimal can be entered (between 0.0 and 25.59).

**ET** Product or volume time.

If WATER is being programmed, the volume in c.c., on machines with a volumetric counter that is going to be dispensed in that step should be programmed instead of the end time.

**MODIFY A STEP- con't**

After choosing the step to edit, start editing. The field to be edited flashes (it can be the field of the name of the hopper, the type of step or one of the digits in the time or volume values).

Button **D** only works when editing the 2nd digit or higher. Finish by pressing **PROG**.

In each step, the start time, the action to be performed and what hopper or blender is going to perform the action and its time in seconds must all be programmed.

After finishing the programming of each step, the screen will display the programming and then the next step can be programmed.

- If **ADD A STEP** has been selected, direct access to the new step will be provided. The procedure is the same as the aforementioned one.
- If **DELETE A STEP** is selected, select the step (pressing 1 or 2) and then delete it (pressing 3).

NOTE: If P is pressed at any time during the programming of a step, programming will be exited and the data will not be recorded

## CH 5 – TROUBLESHOOTING AND MAINTENANCE

### 5.1 Reset

If your machine is out of service, enter and exit programming by pressing the PROG button twice.

### 5.2 Error detected by the machine.

The machine communicates different errors it detects in the normal serving function through different illuminated button combinations.

The following is a list of possible errors:

Message	Possible Causes
<b>LOW TEMPERATURE</b>	The machine displays this warning for approx. 1 min. upon being started up
<b>ERROR: NO WATER</b>	Check the water supply. Fill the water tank
<b>NO COFFEE BEANS</b>	Load the hopper with coffee Check the position of the group outlet shutter
<b>WASTE BIN FULL</b>	Remove the waste tray, clean it and refit it
<b>LONG DISTRIBUTION</b>	Adjust the grinding time to coarser. Clean the group showers Check that there is voltage to the input solenoid.
<b>RESIST. FAULTY</b>	Element broken or disconnected
<b>TEMP SENSOR ERROR</b>	Probe broken or disconnected
<b>FAIL.WATER LEVEL</b>	Check mains pressure. Input solenoid or level ball broken or disconnected.
<b>DOSAGE ERROR</b>	Doser broken or disconnected
<b>F. ESPRESSO UNT POS</b>	The group motor does not work. The position detector does not work properly.
<b>NO WASTE BIN</b>	The tray is missing or not fitted properly.

### 5.3 Changing the product labels

If you have a new set of labels to customize the machine, you can change them as follows:

1. Remove the door COVER. It is mounted on individual fastening elements
2. Release the tab of the labels to change from the retainers
3. Remove the label and insert a new label
4. Secure the tab with the new label using the retainers
5. Fit the door COVER. Make sure that it is properly inserted into its fixing clips.

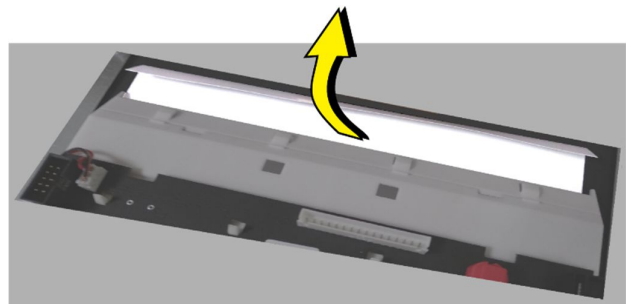
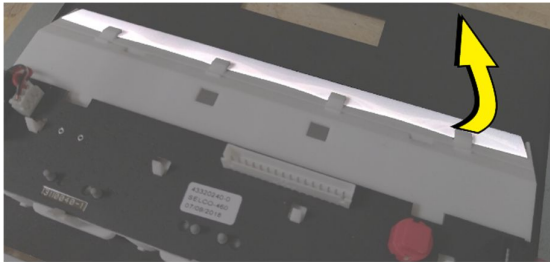



## CH 6- CLEANING THE MACHINE

### 6.1 Components that require regular cleaning

Depending on the number of services that the machine provides, the machine components must be cleaned more or less regularly.

1. Liquid box
2. Box used to store the coffee bean remains (in espresso machines)
3. Mixers
4. Soluble product hoppers
5. Suction tube
6. Coffee bean assembly
7. Front panel of the machine

- 1. Liquid box.** Simply pull from it, lifting it slightly to extract the box and then extract the tray. Espresso machines feature a removable box to store the coffee bean remains, which is built into the liquid tray. When fitting it again, make sure it is inserted correctly and flush to the door.



**The box can be fully removed for cleaning.** To do so, after removing the tray (and emptying the liquids), press the clips under it and remove the front trim. (fig A)

The cup holder can also be removed by pressing on the bottom tab while you pull from it. (fig. B)

To fit it again, insert the small short lower tab first and press on the upper tab until the holder is locked into position.

to position.

A.

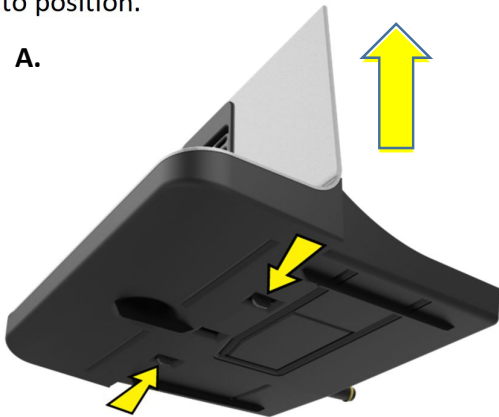

B.

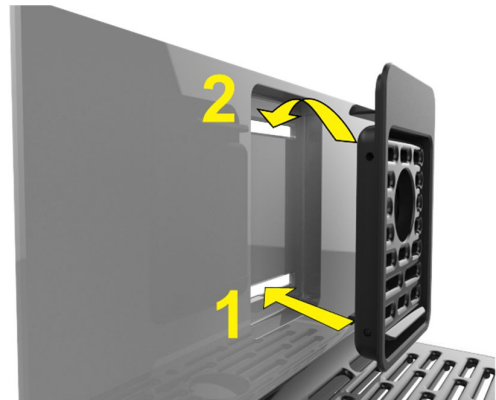



**3. Mixers**

Pull the mixers out to extract and clean or replace it with a clean mixer.

\*Remember to fit the outlet elbows of the hoppers facing upwards to avoid the product from falling out in the machine when the mixer is removed.

When the clean mixer has been inserted, fit the rubber stops again and the outlet elbows onto the hoppers

**4. Soluble product hoppers.**

The soluble product hoppers are extracted by pulling from them up from the top of the machine.

\*Remember to turn the elbows up to prevent the product from falling out and being dropped on the inside of the machine.

If you wish to clean the machine thoroughly, remove the hoppers and remove the suction tube onto which the hoppers are placed (Fig. 1).

**6.2.- Regular cleaning of the machine and maintenance operations**

The following table details the recommended cleaning and frequency:

Once a week or every 700 services	<ul style="list-style-type: none"> <li>• Clean the mixer (Press F)</li> <li>• Clean the surface of the mixer area</li> <li>• Drain the spill tray</li> <li>• Clean the services compartment</li> <li>• Clean the front of the machine after all the above operations have been done</li> </ul>
Once a month or every 5,000 services	<ul style="list-style-type: none"> <li>• Remove the mixer blades. Wash with hot water</li> <li>• Remove the product hoppers and clean the base of the area</li> <li>• Clean intake manifolds</li> </ul>
Once a year or every 25,000 services	<ul style="list-style-type: none"> <li>• Perform all of the above.</li> <li>• Change the coffee filter of the group (see 3.7).</li> <li>• Wash the filter using the Cleaning Cycle (see 6.3), or retreat to thoroughly clean with detergent</li> </ul>
Once every 4 years or every 20,000 services	<ul style="list-style-type: none"> <li>• Check the wheels of the grinder and replace if necessary.</li> </ul>

**6.3 Cleaning cycle for the group brewing chamber**

For hygiene reasons, this process should be performed at least once every three months in order to eliminate coffee particles from the brewing chamber.

**Cleaning cycle for the group brewing chamber cont'd**

Use special detergent tablets for super-automatic coffee machines. There are tablets weighing 2 to 3 g available on the market.

**One-Touch Drinks CAN SUPPLY YOU WITH A KIT OF CERTIFIED TABLETS. REQUEST REFERENCE 09725700 FROM YOUR TECHNICAL SERVICE.**

**Before you start**, remove the liquid tray from the machine. Empty it of solid and liquid waste. Put it back into position on the machine.

You also need a cleaning tablet ready for use.

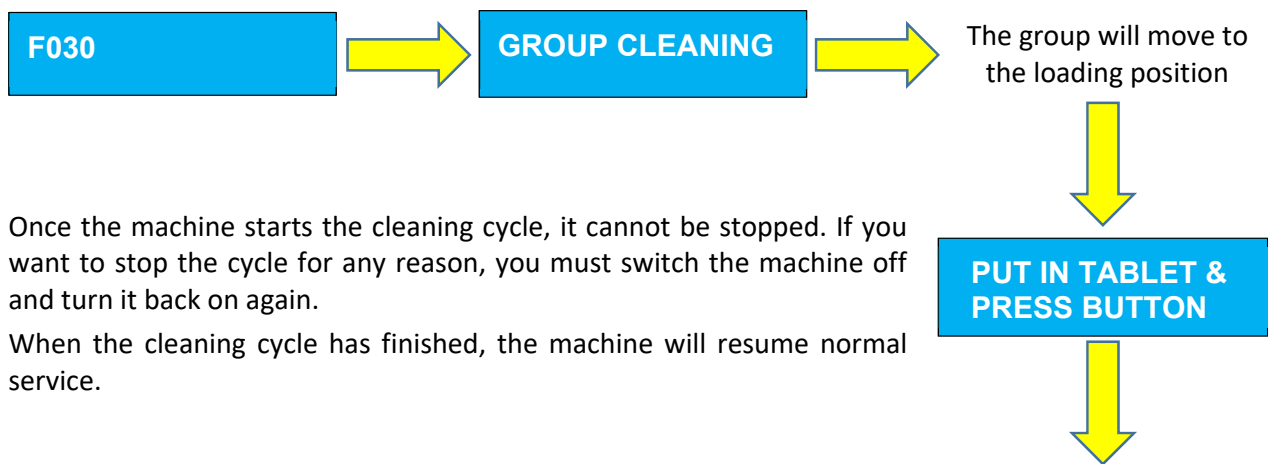

Once the machine starts the cleaning cycle, it cannot be stopped. If you want to stop the cycle for any reason, you must switch the machine off and turn it back on again.

When the cleaning cycle has finished, the machine will resume normal service.

**For correct cleaning**, you should remove the brewing piston and clean the upper filter with cleaning paper or a brush to eliminate any particles which may remain on the filter. To dismantle the piston, follow the instructions in 3.7.

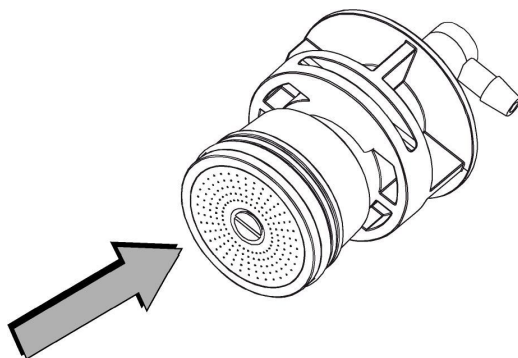

## 6.4 Descaling cycle.

This process should be performed at least once every 3 months unless anti-scale filters or pre-filtered water is being used. The process lasts approximately 30 minutes and must not be cut short.

The benefits obtained from this process are:

- Longer life for your coffee machine
- Prevention of machine operation error codes

If the lime removal process is not completed correctly, lime scale might remain inside the machine. This will generate new lime scale more quickly and could damage the machine.

You will need:

- A satchel of citric acid, Everpure Scalekleen or similar products (do NOT use vinegar).
- A container with a capacity of more than 2 litres to store the water extracted from the tank.



### Process:

1. Pour the contents of the citric acid satchet (100 g) into the tank with 2.5 litres of water (water tank just over half full) and stir with a long utensil, such as a spoon, to dissolve the mixture.
2. Access the group cleaning function via machine test function F030. Select the test “DESCALING”.
3. The cycle begins automatically when the test is selected. Wait until the machine finishes the cycle.
4. Remove the water tank, rinse with clean water and fill it to full. Repeat the same cycle (steps 2 to 6) for a wash cycle and rinse cycle.

## 6.5 Replacing the water filter

The machine may be fitted with a water filter to eliminate impurities, reduce water hardness and avoid unpleasant tastes and blockage in the circuit.

The filter must be changed on a regular basis depending on the hardness of the water used. The following table gives guideline capacities:

Carbonate hardness °KH	Capacity	Cups	
		130 ml	150 ml
6 °KH	242 litres	1860	1610
8 °KH	181 litres	1390	1210
10 °KH	145 litres	1120	970
12 °KH	120 litres	930	810
14 °KH	103 litres	800	690
16 °KH	90 litres	700	600
18 °KH	81 litres	620	540

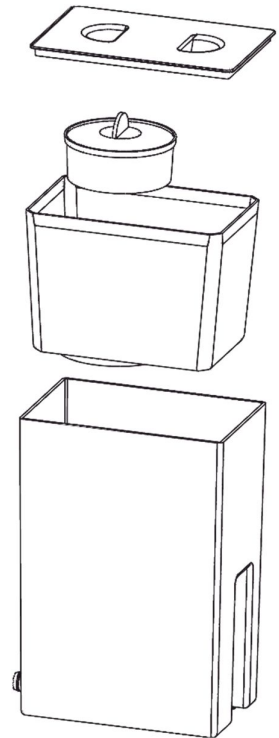

To replace the filter, simply extract the used filter from the tank and insert a new one.

## 6.6 Exterior cleaning



Do not use spray! Use warm water (between 20°C and 40°C) and one of the following products: Washing-up liquid, neutral shampoo, alcohol-free window cleaner.

Rinse with a 2% vinegar (acetic acid) solution and dry with a soft cloth or duster.

If there are stubborn stains (grease, beverages, etc.), use a solution of water and sanitary alcohol (96° Ethanol) at 1 % concentration.

# 1. THE TREATMENT, COLLECTION, RECYCLING AND DISPOSAL OF THIS DEVICE

## DIRECTIVE 2002/96/CE ON THE TREATMENT, COLLECTION, RECYCLING AND DISPOSAL OF ELECTRIC AND ELECTRONIC DEVICES AND THEIR COMPONENTS

### INFORMATION

#### 1. For countries in the european union (EU)

The disposal of electric and electronic devices as solid urban waste is strictly prohibited: it must be collected separately. The dumping of these devices at unequipped and unauthorized places may have hazardous effects on health and the environment. Offenders will be subjected to the penalties and measures laid down by the law.

#### To dispose of our devices correctly

- a) Contact the Local Authorities, who will give you the practical information you need and the instructions for handling the
- b) waste correctly, for example: location and times of the waste collection centres, etc.
- c) When you purchase a new device of ours, give a used device similar to the one purchased to our dealer for disposal.



The crossed dustbin symbol on the device means that:

- When it to be disposed of, the device is to be taken to the equipped waste collection centres and is to be handled separately from urban waste;
- The producer guarantees the activation of the treatment, collection, recycling and disposal procedures in accordance with Directive 2002/96/CE (and subsequent amendments).

#### 2. For other countries (not in the EU)

The treatment, collection, recycling and disposal of electric and electronic devices will be carried out in accordance with the laws in force in the country in question



The manufacturer of the One-Touch Drinks vending system declares under our sole responsibility that our product is in compliance with the essential requirements of the following European Union issued Directives:

- EMC Directive 2014/30/UE, and his modifications
- Low Voltage Directive 2014/35/UE, and his modifications
- RoHS Directive 2015/863/UE
- Regulation 1935/2004, on materials and articles intended to come into contact with food

The product is according with the following norms / standards:

- UNE-EN 60335-2-75:05 +A1:2005+A11:2006 + A2:2008+A12:2010
- UNE-EN 60335-1:2012+AC: 2014+A11:2014
- UNE-EN 55014-1:08 + A1:09+A2:2012
- UNE-EN 55014-2:2015
- UNE-EN 61000-3-2:2014
- UNE-EN 61000-3-3:2013