

## Rio Espresso & Chocolate



### Technical Specifications

<b>Brewing System &amp; Capacity</b>	Espresso	Up to 14 grams per drink
<b>No. of Coffee Bean Hoppers</b>	<b>1</b>	
<b>No. of Drink Selections &amp; Type</b>	Direct touch buttons	8 selections
<b>No. of Soluble Product Canisters</b>	2	Milk, Chocolate, or tea
<b>Canister Capacity</b>	Coffee beans 42 oz / 2.6 lbs Powdered milk 21.6 oz / 1.3lbs Chocolate 28.2 oz / 1.8 lbs	Expand your menu by purchasing an extra canister and fill with a different drink powder to switch with the chocolate canister.
<b>No. of Mixing Bowls</b>	1	
<b>Grinder &amp; Type</b>	1	Flat steel burr blade
<b>Coffee Cakes Capacity</b>	Up to 60 coffee cakes	
<b>Boiler Type &amp; Capacity</b>	Pressure	10.65 oz/ 315 cc capacity
<b>Internal Water Tank Capacity</b>	135 oz	
<b>External Water Supply</b>	Gallon & pump / 1/4" plumbed line	
<b>Auto-cleaning</b>	Functions with hot water after drink services. Can be scheduled.	
<b>Liquids Tray Capacity</b>	28 oz	
<b>Sensors and Filters</b>	Out of coffee beans detector Blocked grinder detector Water temperature and water level control	
<b>Voltage, Maximum Power</b>	110v-120v / 60 Hz	1200 W
<b>Connectivity &amp; Communications</b>	RS232	PC Configuration Software
<b>Base Cabinet (Optional Accessory)</b>	12" (W) x 14"(D) x 34" (H)	

TECHNICAL INFORMATION

DIMENSIONS

**Weight:** 61.5 lb  
**Width:** 12 in  
**Height:** 24 in  
**Depth:** 17 in

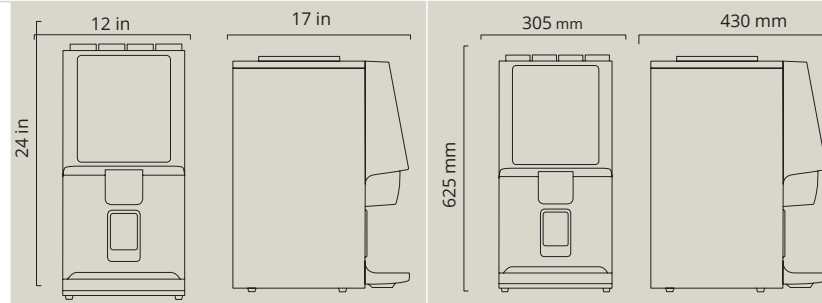

## Rio Espresso & Chocolate

The art of fresh bean espresso, cappuccino, chocolate & tea from *the* most compact super-automatic.

Truly a barista...  
available 24/7.



One-Touch Drinks  
PO Box 118300  
Carrollton, TX 75011-8300

(800) 560-5062  
info@onetouchdrinks.com  
www.onetouchdrinks.com



**One-Touch Drinks** Rio Espresso & Chocolate opens the door to specialty drinks... effortlessly.

Rio is a premium super-automatic, bean-to-cup espresso and hot beverage machine that creates uplifting cafe-quality drinks with little effort and customization. The pleasure of specialty coffee should start with hassle-free creation, and Rio delivers. Its design will attract and impress consumers as it guides them through a pleasant experience. A user-friendly experience and reliable drink service are a product of European engineers' decades of research and development that set One-Touch Drinks machines apart.

Rio Espresso's extra-compact design fits anywhere coffee is desired and provides the highest quality espresso-based and chocolate drinks. It is suited for customer-facing, medium-demand locations that consume up to 250 cups daily, such as restaurants, offices, lounges, convenience stores, gas stations, and hotels. And it is compatible with cashless payment processors.



Enjoy the aroma of freshly ground & brewed coffee by Rio Espresso & Chocolate

Rio caters to diverse tastes by delivering impressive barista-style espresso specialty coffee and chocolate creations. An eight-drink LED button selection controls the menu and is super-easy for new users to understand and operate. Rio makes coffee by grinding fresh coffee beans, tamping, extracting espresso, and steaming pure powdered milk from the canister. A perfect balance of aroma, crema, and flavor, Rio guarantees the correct elements in every drink, all within a minute after the selection.

Rio is quick and easy to maintain, leaving you to focus on what's more important - your business. Rio uniquely allows for two water supplies: an internal tank or through a water line connected to either city tap water or a multi-gallon jug. Wrap Rio to inform the public and increase sales using non-permanent magnets. The best promotional design grabs attention, and the quality and consistently delicious drinks will keep customers returning for more. Rio provides consistent coffee service and will last for 20 years or more.

- Touch Selection
- Touch Buttons
- Sm Cup Holder
- Espresso & Americano
- Soluble
- Single Bean
- Securable Canisters
- Removable Tray
- LED
- Cashless Payments
- Hot water Spout
- Water tank
- NAMA LISTED
- SGS Certification\*
- ECO mode
- Door Lock
- USB & RS232 Connections

\* Complying with UL Standard.



**One-Touch Drinks** Rio Espresso & Chocolate

Design-Features

**Easy to Refill Coffee Beans & Soluble Ingredients**



The filling process can be done from the top without opening the door in a straightforward, simple way.

**Water Options**



A tap water connection kit comes standard and works for longer run time. This is recommended for medium-to-high usage. A 4-liter water tank can be added after factory production for a plug-and-use operation and to use spring water.



**Canister Capacity**  
150 cups Espresso  
150 cups Cappuccino  
40 cups Hot Chocolate

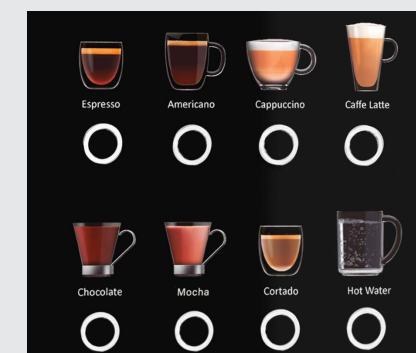

**Easy Order & Label Change**

Easily order drinks from Rio through eight LED lit buttons. Drink decal replacement allows changes to the menu by strips. Change the strip or an additional kit allows changes to individual decals.

**Automatic Cleaning**

Designed to stay hygienic, auto-cleaning routines are quick and thorough with hot water. Schedule auto-cleaning at specific times throughout the day or night and minutes after each drink service.



**The coffee waste bin** has a capacity of up to 60 coffee cakes. It is designed for easy emptying and is dishwasher safe. It can be used with a bag.

**The maintenance tray** is removed from the front which makes maintenance quick and easy for the everyday routine.



**Easy to Clean Waste Trays**

**The liquids tray** has a capacity of 1.2 liter. The design has a built-in wave breaker to avoid unwanted splashes and spills during transport for cleaning.

